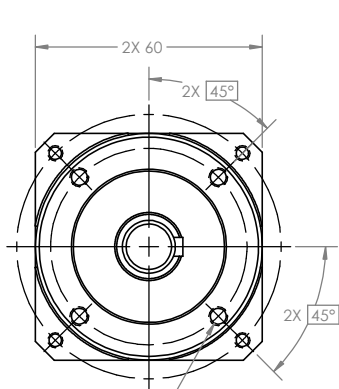

TABLE 1			
PART NUMBER	GEAR RATIO	RATED TORQUE (N-M)	MAX TORQUE (N-M)
CRL60-L1-3	3:1	27	54
CRL60-L1-5	5:1	40	80
CRL-60-L1-10	10:1	16	32

NOTES:

1. MAX RPM @ RATED TORQUE: 8000 RPM
2. RATED RPM @ RATED TORQUE: 4000 RPM
3. BACKLASH: 8 ARCMIN
4. FULL LOAD EFFICIENCY: 95%
5. NOISE: 58 dB
6. OPERATING TEMP: 14F TO 194F
7. RATED TORQUE: SHOWN PER TABLE 1
8. MAX TORQUE: SHOWN PER TABLE 1



4X Ø 4.20 ∇ 12.40
 M5X0.8 - 6H ∇ 10.00
 ON A 52 BCD

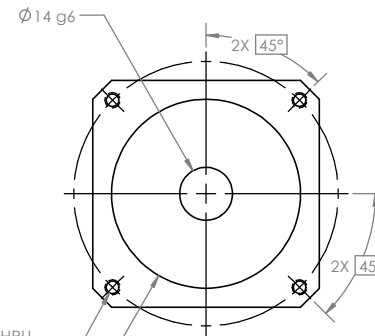
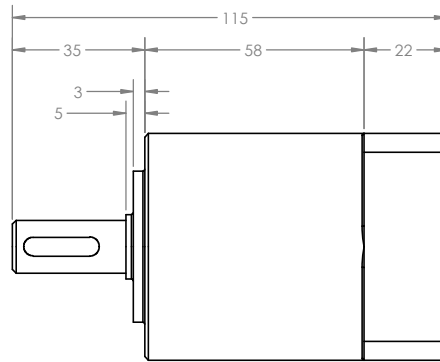

4X Ø 3.30 THRU
 M4X0.7 - 6H THRU
 ON A 70 BCD

Ø 50 g6

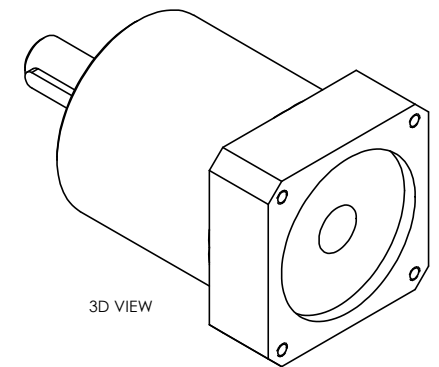
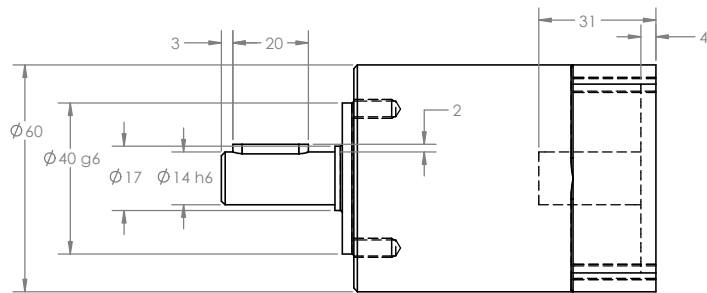

3D VIEW

CRL60-L1	/ 01
PART NUMBER / REV	
UNLESS OTHERWISE SPECIFIED: DIMENSIONS ARE IN METRIC TOLERANCES: .25 .14 .12 .08 .075 .05 .03 .02 .01 .01 .005 .005 .002 .002	
DO NOT SCALE DRAWING.	
DIMENSIONING AND TOLERANCING IN ACCORDANCE WITH ASME Y14.5 2009.	

PROPRIETARY AND CONFIDENTIAL
 THIS DATA IS OF CONFIDENTIAL AND PROPRIETARY NATURE AND IS PROPERTY OF COVALDO INDUSTRIES LLC AND SHALL NOT BE REPRODUCED IN ANY MANNER NOR DISCLOSED TO OTHERS OR USED FOR ANY PURPOSE WHAT SO EVER, EXCEPT BY WRITTEN PERMISSION FROM COVALDO INDUSTRIES LLC.

HARD COPIES ARE TO BE CONSIDERED UNCONTROLLED

ODD DASH NUMBERS SHOWN NEXT HIGHER CONSECUTIVE EVEN DASH NUMBERS OPPOSITE

3D ANGLE PROJECTION

1959 N. Peace Have Rd. Winston-Salem, NC 27106	
TITLE: PLANETARY GBX	
SIZE C	DWG. NO. CRL60-L1
SCALE: 1:1	WEIGHT: SHEET 1 OF 1
REV 01	