

4

3

2

1

D

D

C

C

B

B

A

A

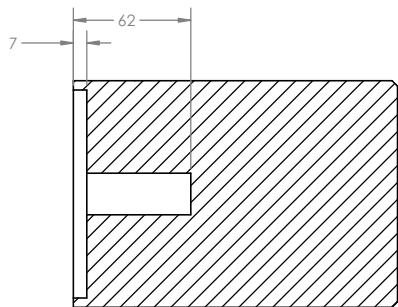
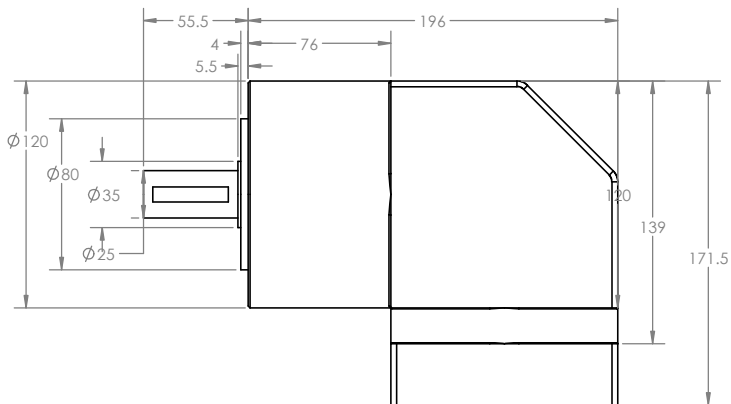
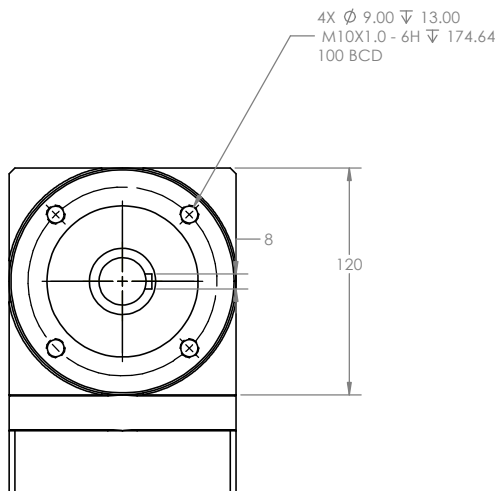

SECTION D-D

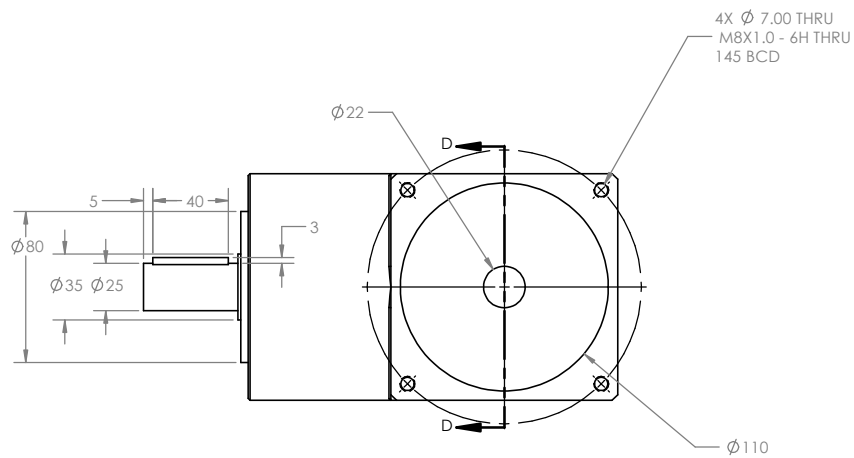

CVL120-L1 / A	
PART NUMBER / REV	
UNLESS OTHERWISE SPECIFIED:	
DIMENSIONS ARE IN METRIC	
DECIMALS:	ANGLES: 1/2 DEG
1/16 1/32	1/16 1/32
DO NOT SCALE DRAWING.	
DIMENSIONING AND TOLERANCING IN ACCORDANCE WITH ASME Y14.5 2009.	

PROPRIETARY AND CONFIDENTIAL	
THIS DATA IS OF CONFIDENTIAL AND PROPRIETARY NATURE AND IS PROPERTY OF COVALD INDUSTRIES LLC AND SHALL NOT BE REPRODUCED IN ANY MANNER NOR DISCLOSED TO OTHERS OR USED FOR ANY PURPOSE WHATSOEVER, EXCEPT BY WRITTEN PERMISSION FROM COVALD INDUSTRIES LLC.	
HARD COPIES ARE TO BE CONSIDERED UNCONTROLLED	
ODD DASH NUMBERS SHOWN NEXT HIGHER CONSECUTIVE EVEN DASH NUMBERS OPPOSITE	
3D ANGLE PROJECTION	

1959 N. Peace Have Rd. Winston-Salem, NC 27106		
TITLE: RIGHT ANGLE GEARBOX		
SIZE	DWG. NO.	REV
C	CVL120-L1	A
SCALE: 1:2	WEIGHT:	SHEET 1 OF 2

DWN BY/DATE: COVALD INDUSTRIES / 8/24/2024

APPRV BY/DATE: /

4

3

2

1

DWG. NO.: CVL120-L1B

NOTES:

- 1. MAX RPM @ RATED TORQUE: 6000 RPM
- 2. RATED RPM @ RATED TORQUE: 3500 RPM
- 3. BACKLASH: 8 ARCMIN
- 4. FULL LOAD EFFICIENCY: 95%
- 5. NOISE: 65 dB
- 6. OPERATING TEMP: 14F TO 194F
- 7. RATED TORQUE: SHOWN PER TABLE 1
- 8. MAX TORQUE: SHOWN PER TABLE 1

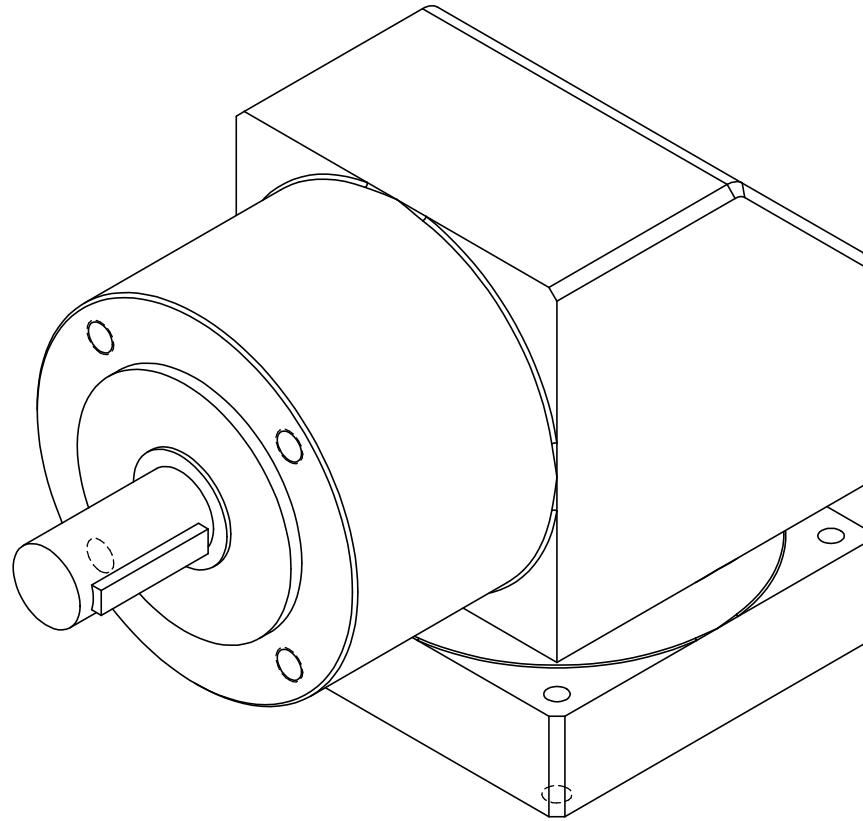

3D VIEW

TABLE 1

PART NUMBER	GEAR RATIO	RATED TORQUE (N-M)	MAX TORQUE (N-M)
CVL120-L1-3	3:1	161	322
CVL120-L1-5	5:1	210	420
CVL-120-L1-10	10:1	86	172

CVL120-L1 / A
PART NUMBER / REV
UNLESS OTHERWISE SPECIFIED: DIMENSIONS ARE IN METRIC TOLERANCES: H .154 M .254 S .305 X .381 DO NOT SCALE DRAWING.
ANGLE 1/2 DEG
DIMENSIONING AND TOLERANCING IN ACCORDANCE WITH ASME Y14.5 2009.

PROPRIETARY AND CONFIDENTIAL THIS DATA IS OF CONFIDENTIAL AND PROPRIETARY NATURE AND IS PROPERTY OF COVALO INDUSTRIES LLC AND SHALL NOT BE REPRODUCED IN ANY MANNER NOR DISCLOSED TO OTHERS OR USED FOR ANY PURPOSE WHATSOEVER, EXCEPT BY WRITTEN PERMISSION FROM COVALO INDUSTRIES LLC.	
HARD COPIES ARE TO BE CONSIDERED UNCONTROLLED	
ODD DASH NUMBERS SHOWN NEXT HIGHER CONSECUTIVE EVEN DASH NUMBERS OPPOSITE	
3D ANGLE PROJECTION	

1959 N. Peace Have Rd. Winston-Salem, NC 27106	
TITLE: RIGHT ANGLE GEARBOX	
SIZE C	DWG. NO. CVL120-L1
SCALE: 1:2	WEIGHT: SHEET 2 OF 2